

# LED Wallpack Light

Model # WP11-80[N;T]-[D;M;P]-50



# JAMES

Industrial Supply Products

## Product

LED full-size wall packs project a bright, clean light and reach full brightness instantly. They use LED lamps, which last longer and use significantly less energy than wall packs with other lamp types, such as high-pressure sodium or compact fluorescent. They also produce very little heat and can withstand temperature changes and humidity. These wall-mounted outdoor lighting fixtures are commonly used to replace traditional lighting wall packs on commercial and industrial buildings.



## Technical Data

Brand	RZ Lighting
Light Output	10797.5 lm
Wattage	79.2W
CRI	72
Total Harmonic Distortion	23.5 %
Lumen Efficiency	136.3 lumens per Watt
Input Voltage	AC 100 ~ 347V
Frequency	50/60 Hz
Dimming Status	Continuous Below 10
Rated Life	50,000+ Hours
Power Factor	0.915
Color Temperature	5000K



## Features

- Traditional design, familiar footprint
- Up to 100,000 hour operating life (L85)
- Energy Saving – Energy Saving of 79% compared to equivalent HID lighting sources over product's lifespan.
- 10 kV, field replaceable surge protector

## Dimensions

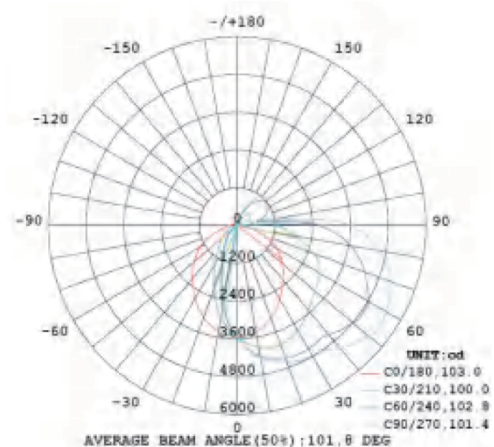
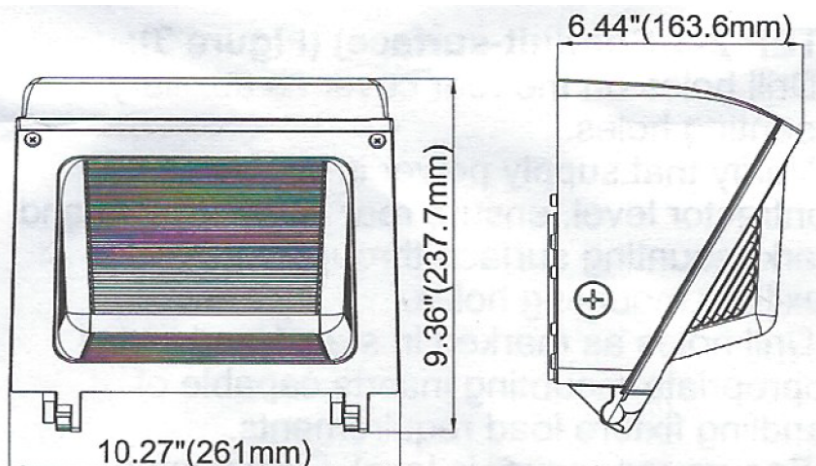

## Warranty

The manufacturer warrants this product to be free from defects in workmanship and materials, under normal residential use and conditions, for a period of five (5) year for the original invoice date. Shipping and handling fees are to be paid for by the customer. The manufacturer agrees, at its option during the warranty period, to repair and defect in material or workmanship or to furnish a repaired or refurbished product of equal value in exchange without charge (except for a fee for shipping, handling, packing, return postage, and insurance which will be incurred by the customer). Such repair or replacement is subject to verification of the defect or malfunction and proof of purchase as confirmed by showing the model number on original dated sales receipt.