

# LED Traditional Wall Pack



# JAMES

Industrial Supply Products

Model # RZ-WP-XXW-750



LED full-size wall packs project a bright, clean light and reach full brightness instantly. They use LED lamps, which last longer and use significantly less energy than wall packs with other lamp types, such as high-pressure sodium or compact fluorescent. They also produce very little heat and can withstand temperature changes and humidity. These wall-mounted outdoor lighting fixtures are commonly used to replace traditional lighting wall packs on commercial and industrial buildings.

## Technical Data

Model #	RZ-WP-60W	RZ-WP-80W	RZ-WP-100W	RZ-WP-120W
Light Output	7794.66 lm	9969 lm	12066.6 lm	14511 lm
Wattage	63 W	80.33 W	94.13.5 W	118.6 W
CRI	71.3	71.8	71.2	84.1
Total Harmonic Distortion	8.79%	8.31%	8.07%	13.53%
Lumen Efficiency	123.45 lm/W	124.1 lm/W	128.19 lm/W	122.34 lm/W
Input Voltage	AC 120 ~ 270V			
Color Temperature	5000K			
Frequency	50/60 Hz			
Dimming Status	Not Dimmable			
Rated Life	50,000+ Hours			
Power Factor	0.99			
Housing	Die-Cast Aluminum & PC			

# LED Traditional Wall Pack



Industrial Supply Products

Model # RZ-WP-XXW-750

60W 80W Model Dimension

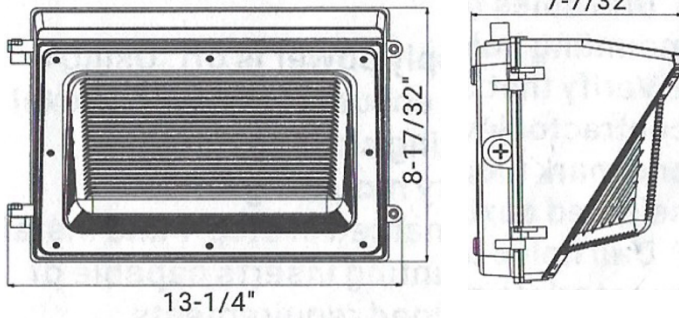

100W 120W Model Dimension

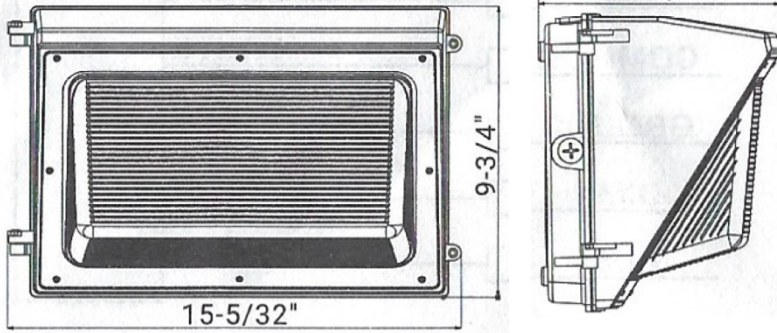

## Photometric Data (RZ-WP-80W)

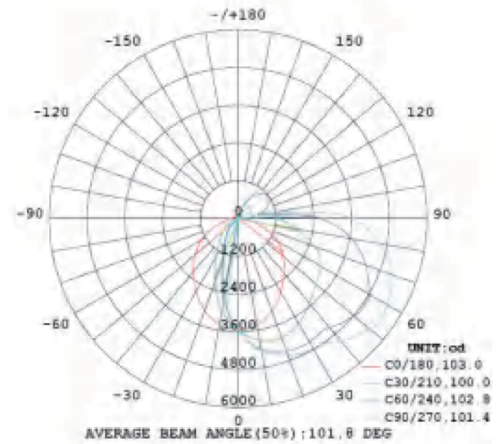

## Accessories



LED Fixture 120 -  
277V 50/60Hz Input



Photocell Sensor  
(Optional)



Emergency Battery  
Backup (Optional)

## Warranty

The manufacturer warrants this product to be free from defects in workmanship and materials, under normal residential use and conditions, for a period of five (5) year for the original invoice date. Shipping and handling fees are to be paid for by the customer. The manufacturer agrees, at its option during the warranty period, to repair and defect in material or workmanship or to furnish a repaired or refurbished product of equal value in exchange without charge (except for a fee for shipping, handling, packing, return postage, and insurance which will be incurred by the customer). Such repair or replacement is subject to verification of the defect or malfunction and proof of purchase as confirmed by showing the model number on original dated sales receipt.